

CHANGE HISTORY			
REV	DESCRIPTION	DONE BY	DATE
P1	PRELIMINARY RELEASE	P GRAY	15 OCT 05
P2	REVISED PER REVIEW WITH MANUFACTURER (DANAHER LINEAR)	P GRAY	17 OCT 05
P3	REVISED PER FURTHER REVIEW WITH MANUFACTURER (DANAHER LINEAR)	P GRAY	24 OCT 05
P4	UPDATED FORMAT	P GRAY	19 DEC 05

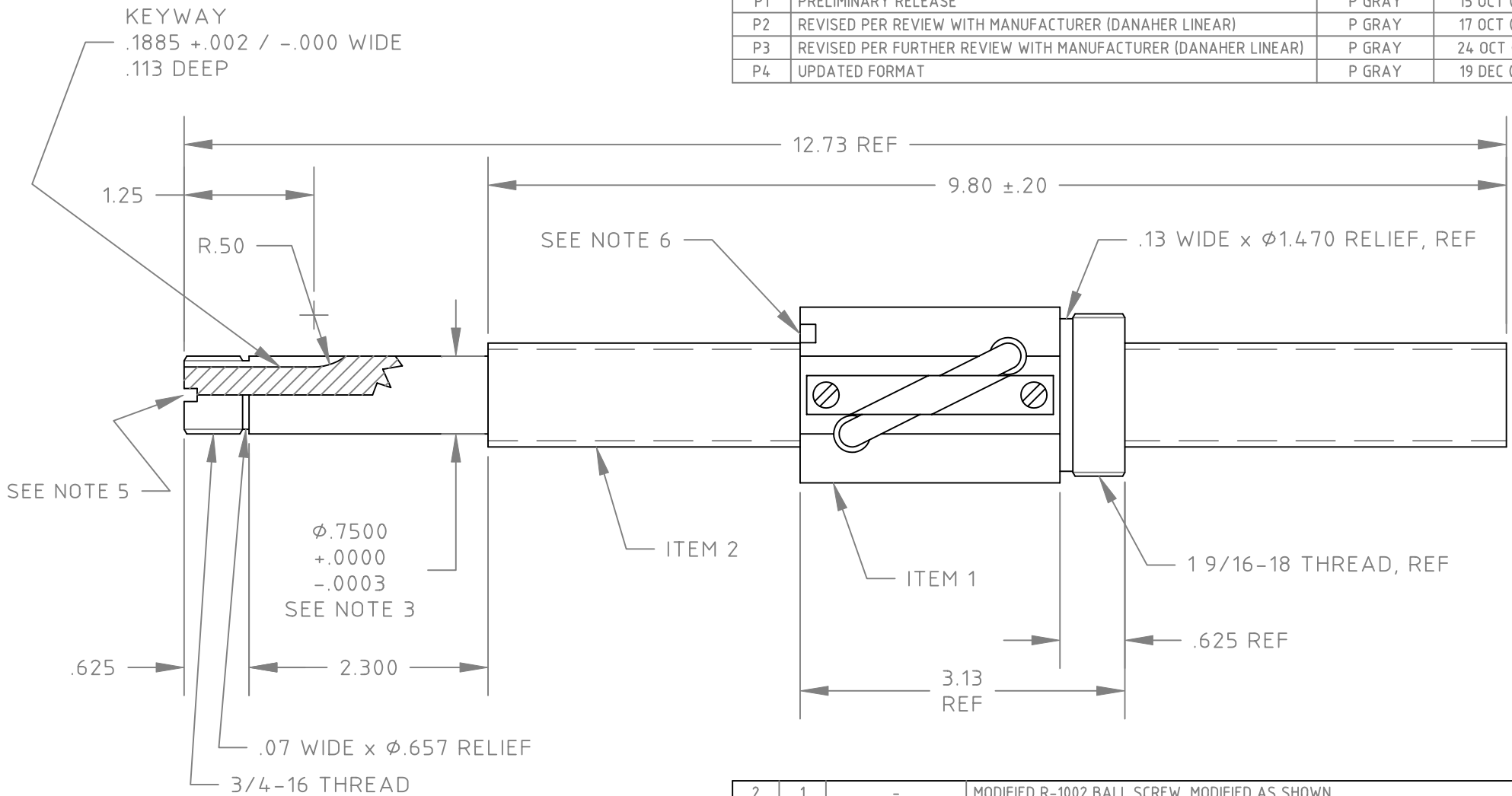

6. .25 WIDE x .15 DEEP SLOT ACROSS FULL FACE OF NUT, PROVIDING TWO WRENCH NOTCHES, ONE ON BOTH SIDES OF SCREW
5. .125 WIDE x .125 DEEP SLOT ACROSS END OF SHAFT PERMISSIBLE
4. CENTERS PERMISSIBLE
3. .750 DIAMETER:
 - GRIND TO 16 FINISH
 - OUT OF ROUND TOLERANCE .0001 MAX
 - HARDEN TO RHc 56 - 61, CASE DEPTH .030 MIN
2. FINISH: N/A
1. MATERIAL: R-1002 SERIES DANAHER LINEAR BALL SCREW

NOTES:

ITEM	QTY	PART NUMBER	DESCRIPTION
2	1	-	MODIFIED R-1002 BALL SCREW, MODIFIED AS SHOWN
1	1	-	STANDARD R-1002 BALL NUT, DANAHER LINEAR P/N 8110-448-022
-	-	DC-01-0200-11	DANAHER LINEAR PART NUMBER FOR ASSEMBLY: R-1002-41196

PARTS LIST

UNLESS OTHERWISE SPECIFIED:
 DIMENSIONS ARE IN INCHES
 DIMENSIONS APPLY AFTER PLATING
 BREAK ALL SHARP EDGES
 DO NOT SCALE DRAWING
 MAXIMUM INSIDE CORNER RADIUS: .005

TOLERANCES:
 X/X +/- .03
 .XX +/- .015
 .XXX +/- .005
 ANGLES +/- 1°

Door Control Services, Inc.

321 VZ County Road 4500, Ben Wheeler, TX 75754 Tel: 800.437.3667

PROPRIETARY NOTICE
 THIS DRAWING AND ALL INFORMATION CONTAINED
 HEREIN IS THE PROPERTY OF DOOR CONTROL SERVICES,
 INC. AND IS NOT TO BE COPIED, DUPLICATED OR IN ANY
 WAY USED AS THE BASIS FOR MANUFACTURE OR
 SALES WITHOUT WRITTEN PERMISSION.

THIRD ANGLE PROJECTION

DRWN BY	P GRAY	DATE	10 OCT 02
CHKD BY	-	DATE	-
APPD BY	-	DATE	-

PART NAME / DESCRIPTION

BALL SCREW ASSEMBLY

DRAWING / PART NUMBER

DC-01-0200-11

SCALE 2:3 SHEET SIZE A SHEET 1 OF 1